

Experimental Model of the Interfacial Instability in Aluminium Reduction Cells

A.Pedchenko,* S. Molokov,† and J.Priede
Applied Mathematics Research Centre, Coventry University, UK

A.Lukyanov
University of Reading, UK

P.J.Thomas
Fluid Dynamics Research Centre, Warwick University, UK

A solution has been found to a long-standing problem of experimental modelling of the interfacial instability in aluminium reduction cells. The idea is to replace the electrolyte overlaying molten aluminium with a mesh of thin rods supplying current down directly into the liquid metal layer. This eliminates electrolysis altogether and all the problems associated with it, such as high temperature, chemical aggressiveness of media, products of electrolysis, the necessity for electrolyte renewal, high power demands, etc. The result is a room-temperature, versatile laboratory model which represents Sele-type, rolling pad interfacial instability. The method can be used to obtain detailed experimental data and to test various theoretical models, which has never been done before

PACS numbers:

Overcoming magnetohydrodynamic (MHD) instabilities in aluminium reduction cells is a problem of enormous industrial importance [1]. This is not surprising as current production facilities consume about 3% of all the electricity generated worldwide, which translates into about \$10 billion annually [2]. Thus the efficiency of the process of aluminium smelting has considerable economic dimension.

Aluminium is produced in rows of about 100 shallow baths or cells with horizontal dimensions of 4 - 5 m by 10 - 16 m each by passing an electric current of between 150 and 500 kA through a mixture of alumina (Al_2O_3) and cryolite (sodium aluminium fluoride) (Fig. 1). The electric current flows vertically down from the carbon anodes at the top of the cell to the carbon cathode at the bottom, melting both alumina and cryolite by means of Joule heating. As a result of very complex thermo-, electro-, hydro-, magneto- dynamic, and electro-chemical processes involving consumption of carbon from anodes and accompanying CO_2 and perfluorocarbon gas emissions, a two-fluid layer is formed, about 30 cm deep. The fluid on top, about 4-5 cm thick, is an electrolyte with very poor electrical conductivity of $\sigma_c \approx 200(\Omega m)^{-1}$ while the fluid below is a slightly heavier molten aluminium with high conductivity of $\sigma_a \approx 3 \times 10^6(\Omega m)^{-1}$. Both are kept at about $960^\circ C$.

The interface between the electrolyte and the liquid metal may become unstable to MHD waves if parameters of the process rise above or fall below certain thresholds. The key to the mechanism of instability, suggested first by Thornlief Sele [3], is the MHD interaction of the horizontal component of the disturbance electric current

\mathbf{j} (see Fig. 1), which flows mainly in highly conducting aluminium layer with the vertical component of the background field B_0 . The Lorentz force $\mathbf{f} = \mathbf{j} \times \mathbf{B}_0$ (see Fig. 2) drives the metal into horizontal motion (pos. 2) resulting in a rotating interface, which under certain conditions may become unstable. The background magnetic field is an unwanted side effect of the bus bars supplying the current to the cells, which cannot be totally eliminated.

The electrodynamic role of the electrolyte is simple: to pass the current vertically down into the aluminium (2, pos. 1) for the following obvious reason. The electrolyte is a very poor conductor, which implies that the electric current flows in the direction of least resistance, mainly vertical. The electric potential difference across the electrolyte layer results in many undesirable accompanying features of electrolysis, such as high power demands and generation of gases and harmful products of chemical reactions.

Direct measurements of fluid flow in the cells are very limited due to high temperature and chemical aggressiveness of the melts. Two types of measurements are widely

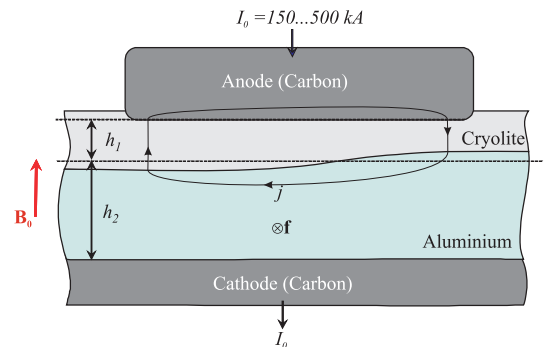

Figure 1: Schematic diagram of the aluminium smelting process

*Electronic address: a.pedcenko@coventry.ac.uk

†Electronic address: s.molokov@coventry.ac.uk

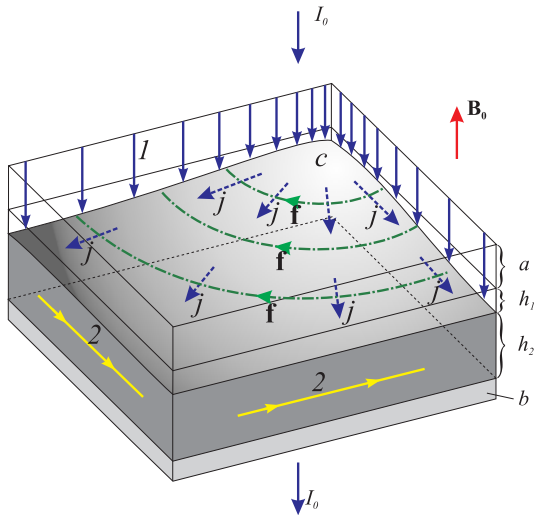

Figure 2: Schematic diagram of the instability mechanism; a - anode, b - cathode, c - deformed liquid metal surface, h_1 - cryolite, h_2 - molten aluminium, 1 - vertical current entering aluminium, j - horizontal disturbance current in the aluminium layer, f - the direction of the Lorentz force, 2 - the direction of the rotating wave

used. The first one is the iron rod method, whereby a rod is dipped into aluminium and the intensity of the fluid flow is judged by the rate of dissolution of the rod over a prolonged period of time [4]. The other method consists of measuring the global potential difference between the anodes and the cathode, which gives the variation of the total resistance of the cell with time, and thus to make conclusions about the unsteady fluid flow.

Needless to say that neither of these methods is precise. It is thus not surprising that most studies of the instabilities have been theoretical, see the review in [5], suggesting various mechanisms and flow models, but none of these models has been verified experimentally. Thus the necessity for a safe, cold model of the cell involving non-aggressive fluids cannot be overestimated.

Here we present a solution for experimental modelling, which eliminates the necessity to use the electrolyte and thus electrolysis altogether allowing to create a low-temperature versatile laboratory model which reproduces Sele-type of instability. In this model the electrolyte is replaced by a system of thin vertical rods connected to the anode plate and dipped directly into the liquid metal. This fulfils the electrodynamic role of the electrolyte to conduct current vertically down into the liquid metal but at the same time eliminates all the problems related to high temperatures, aggressiveness of the electrolyte, products of the electrolysis, electrolyte renewal, high power demands, etc.

The experimental cell depicted schematically in Fig. 3 represents a container with square horizontal cross-section with dimensions $30 \times 30 \text{ cm}^2$. The box has 15-cm-high, electrically insulating, polycarbonate side walls and a stainless steel bottom. It is filled with a thin layer of

metal, In-Ga-Sn, as a substitute for aluminium, which remains liquid at room-temperature. This metal is widely used in MHD experiments.

The electric current is supplied to the layer from the anode, located at the top of the cell. The anode is a 15-mm-thick copper plate with 900 electrodes made of stainless steel, which are 40 mm long and 2 mm in diameter. The electrodes are inserted into the bottom surface of the anode plate and distributed uniformly with a 10 mm pitch. Being directly immersed into the liquid metal with their tips, these electrodes conduct the electric current between the nearly equipotential anode plate and the liquid metal. The immersion depth of the electrodes may be varied by lowering or lifting the anode plate. The surface of the liquid metal is free to move along the electrodes in the gap with the anode plate.

The effective conductivity of the system of steel electrodes is 75 times lower than the one of the same height of liquid metal. Thus the electrodynamic properties of the electrodes are similar to those of the electrolyte. If the liquid metal rises in some area of the cell, the length of the electrodes (and hence their resistance) in that region reduces, causing higher current in that area of liquid metal. For cell areas with lower level of liquid metal the resistance of the electrodes becomes higher which results in lower current. In other words, the interface shape is driving non-homogeneity of the anode current, which enters the liquid metal and redistributes horizontally within the liquid metal layer before entering the steel bottom with lower electrical conductivity.

The space between the anode plate and the liquid metal surface has been filled with a weak ($\sim 3\%$) alcohol and HCl solution to minimise oxidation of the liquid metal surface, to avoid liquid metal sticking to the side walls during sloshing, and to provide some cooling for the anode electrodes in case of the electric contact in-

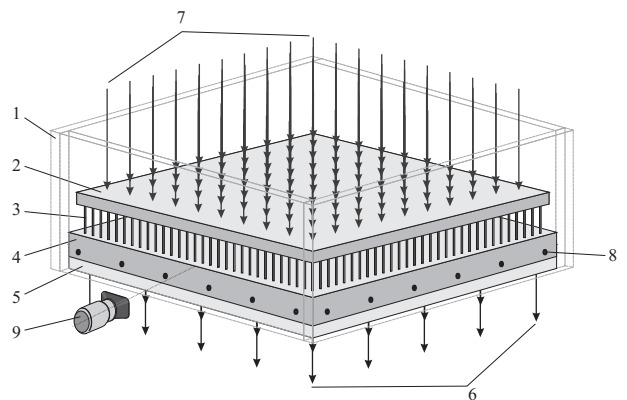

Figure 3: Sketch of the experimental model: 1 - Lexan side walls, 2 - copper anode plate, 3 - 900 stainless steel electrodes, 4 - liquid metal, In-Ga-Sn, 5 - stainless steel cathode plate, 6 - wires supplying current to the anode (100 pcs.), 7 - wires collecting current from the cathode (25 pcs.), 8 - electric potential probes, 9 - CCD camera for tracking the elevation of the liquid metal

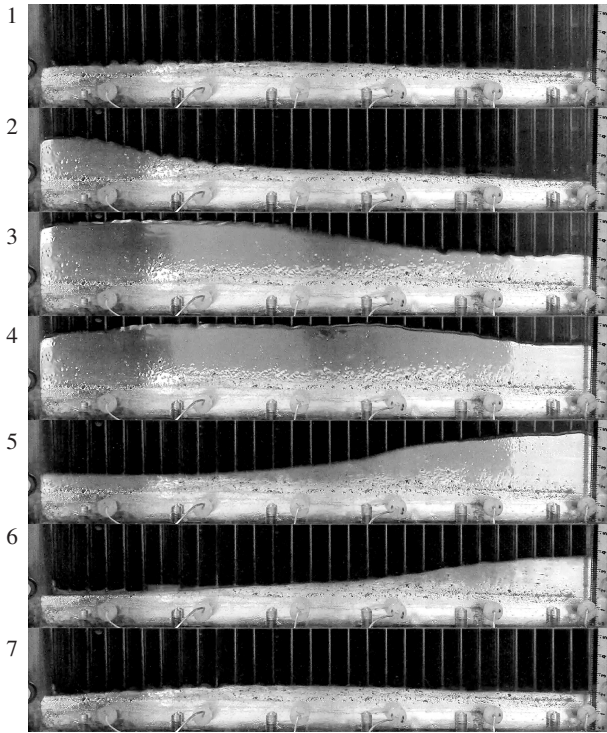

Figure 4: Sequence of video frames showing passing liquid metal wave along a sidewall of the cell; time step between the frames is 0.2 s; wave period is 1.2 s; $h_2 = 35$ mm, $I_0 = 1.2$ kA, $B_0 = 100$ mT; vertical scale is 55 mm per frame.

terruption between some of the electrodes and the liquid metal. This second liquid, however, does not conduct electric current, but may serve to minimise density difference between the fluids thus making interfacial waves less stable.

Maximal anode current in the experiment has been 1.8 kA, which allows to achieve the maximal current density in the experiment of $2.2A/cm^2$. This is more than 4 times higher than that in real cells. The background magnetic field is generated by two induction coils (not shown in Fig. 3) surrounding the cell. The cell is placed in the gap between these two coils (*Helmholtz* configuration), in the region where the magnetic field has only vertical component with non-uniformity over the horizontal cross-section of the liquid metal of $\sim 5\%$ and the absolute value of up to 0.1T. The maximum magnetic field is 20 times higher than that in real cells.

To register oscillations in the liquid metal two measurement techniques have been used: (I) recording the distribution of the electric potential ϕ at the sidewalls along the perimeter of the cell (Fig. 3, pos. 8) and (II) tracking the elevation of the liquid metal at a fixed point along the cell perimeter with CCD camera (Fig. 3, pos. 9).

Twenty four electric potential probes installed in the side walls of the cell, 10 mm above the bottom, are equally distributed along the perimeter to measure instantaneous values of ϕ at these locations with reference

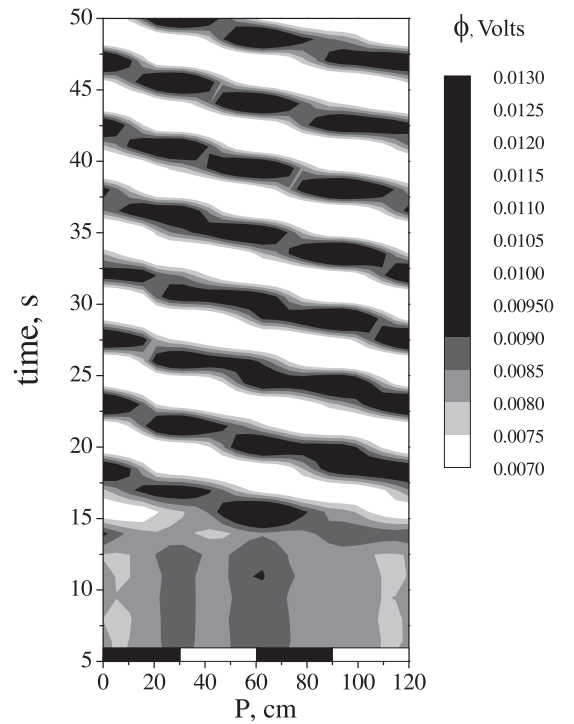

Figure 5: Time-spatial distribution of the electric potential along the perimeter of the cell P; initial stage (5..15 s) corresponds to the onset of the wave; black and white bars at the bottom of the graph show the sidewalls of the cell.

to a point at the centre of the cell. The electric potential at the sidewalls is related to the horizontal current by means of Ohm's law, $\mathbf{j} = -\sigma_{\mathbf{a}} \nabla \phi$, where ∇ is the gradient vector in the horizontal plane. Thus ϕ gives information about the strength of the disturbance Lorentz force \mathbf{f} at the sidewalls. The measurements of the sidewall potential also provide qualitative information on the overall behaviour of the liquid metal surface as ϕ is related to the elevation of the interface [6], [7].

The second measurement technique used in the experiment is high-resolution video recording of the liquid metal elevation in the middle of a sidewall (Fig. 3, pos. 9) with the frame rate of 30 fps. This data provides quantitative information about the amplitude of the liquid metal height oscillations, waveform, frequency and spectrum.

The procedure of the experiments has been as follows: first, the anode is lowered for the electrodes to immerse into the liquid metal. Next, the anode current is switched on to the maximum value of 1.8 kA and after that a vertical magnetic field is applied. Once instability sets in, the current is lowered to the desired value.

If the value of B_0 is high enough to provide an initial perturbation of the surface during the transient, the instability evolves rapidly. It manifests itself as a rotating wave of finite amplitude with counter-clockwise direction of rotation (assuming \mathbf{B}_0 points up and \mathbf{I}_0 flows down). Changing the direction of \mathbf{B}_0 to the opposite changes

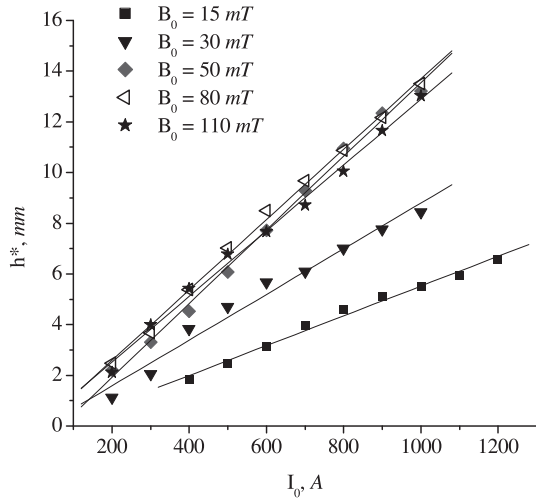

Figure 6: RMS value of interface fluctuations h^* vs. current I_0 .

the direction of rotation. The sequence of video frames in Fig. 4 demonstrates a high-amplitude wave passing along one of the sidewalls of the cell.

Fig. 5 provides time-history of the measured electric potential along the sidewalls. It clearly represents a wave rotating along the perimeter of the cell with a single frequency. The obtained map of the potential correlates very well with optical observations of the oscillations of the liquid metal interface. At low amplitudes of the wave, its propagation rate measured for different liquid metal heights h_2 is slightly above the phase speed of the interfacial gravity waves for two immiscible liquids given by [5]:

$$c_0 = \sqrt{\frac{g(\rho_1 - \rho_2)}{\frac{\rho_1}{h_1} + \frac{\rho_2}{h_2}}}, \quad (1)$$

as predicted by linear stability theories (see e.g. [7]). Here ρ_1, ρ_2 are densities and h_1, h_2 are heights of lower and upper liquid respectively.

The amplitude of the wave varies in a wide range of 3...50 mm increasing with the anode current I_0 and the magnetic field B_0 . The frequency of the wave observed in the experiment varies with the thickness h_2 of the liquid metal layer in the range of 0.5...0.9 Hz for $h_2 = 10...45$ mm.

The amplitude of the liquid metal surface oscillations is found to depend linearly on the anode current I_0 . This is demonstrated in Fig. 6 for several values of the external magnetic field B_0 . One can see that for higher induction of the magnetic field, up to about 50 mT the surface oscillations are higher. For $B_0 > 50$ mT there is almost no dependence on B_0 . This implies that the damping in the system by the magnetic field starts varying linearly with B_0 thus compensating the destabilizing Lorence force \mathbf{f} , also linearly dependent on B_0 .

Besides the anode current and the vertical magnetic field strengths, the amplitude of the wave depends on the thickness of the liquid metal in the cell. It is higher for lower levels of the liquid metal.

The facility has been successfully used to reproduce Sele-type of instability thus opening the way to more detailed experimental studies and to verification of various theoretical models, which has never been done in practice before.

This work has been performed within the Aluminium Smelter Project No. 2005-3-2723-7 funded by Carbon Trust (UK), Rio Tinto Alcan, Coventry University and University of Warwick.

-
- [1] K. Moffat, in *Perspectives in Fluid Dynamics. A collective introduction on current research*, edited by G. Batchelor, H. K. Moffatt, and M. G. Worster (Cambridge University Press, Cambridge, 2000), chap. 7, pp. 347–391.
 [2] P. A. Davidson, *Mater. Sci. Technol.* **16**, 475 (2000).
 [3] T. Sele, *Light Metals* pp. 313–322 (1997).
 [4] G. da Mota and J. Blasques, *TMS Light Metals* pp. 185–190 (2004).
 [5] J.-F. Gerbeau, C. L. Bris, and T. Lelievre, in *Mathematical*

- Methods for the Magnetohydrodynamics of Liquid Metals*, edited by G. Golub, A. Greenbaum, A. M. Stuart, and E. Suli (Oxford University Press, 2006), Numerical Mathematics and Scientific Computation, chap. 6, pp. 233–302.
 [6] A. Lukyanov, G. El, and S. Molokov, *Physics Letters A* **290**, 165 (2001).
 [7] V. Bojarevics and M. Romerio, *Eur. J. Mech. BFluids* **13**, 33 (1994).